

Septum Polarizers and Feeds

Paul Wade, W1GHZ ©2003

The septum feed^{1,2} was first described by Zdenek, OK1DFC, at the 10th International EME Conference 2002 in Prague. On-the-air results were promising, but, like any new antenna, there were questions as to how well it really works. To find out, I ran some computer simulations and published the results³ suggesting that this feed should work well, and also suggesting some variations to allow use over a range of dish f/D. However, I later realized that I was not properly analyzing the circular polarization, so this paper includes revised analysis of the previous feeds as well as additional results.

OK1DFC septum feed

The septum feed as described by OK1DFC is an unflared square horn, or simply a square waveguide, with an internal stepped septum to generate circular polarization. Figure 1 is the view looking into the horn, and Figure 2 is a photo of a partially assembled feed with the septum in place, and Figure 3 is a cartoon of a septum feed. The horn is excited by inputs on either side of the septum, with the two sides

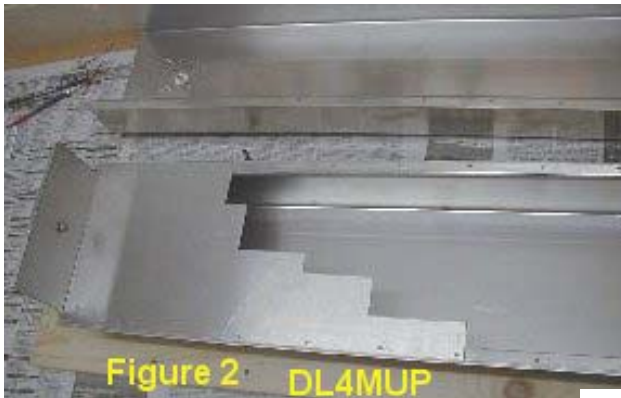

exciting opposite senses of circular polarization. For EME, this provides separate transmit and receive ports of opposite sense of polarization – reflecting off the moon reverses the sense of the polarization. The excitation may come from two rectangular waveguides, each

matching the dimensions of one-half of the square horn, or from a perpendicular probe on each side of the septum acting as an integral transition from coax to the waveguide. The two methods should provide identical results provided that the waveguide section before the septum is long enough to suppress any spurious modes.

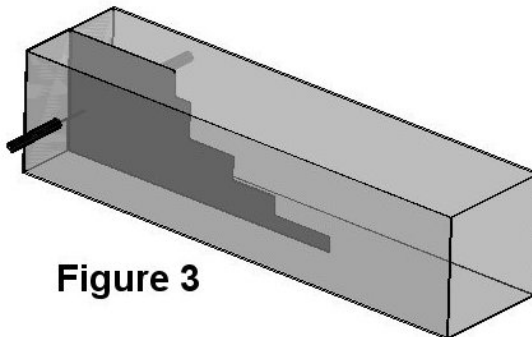

The radiating element, at the aperture, is simply a square horn. Rotated 45 degrees, it is identical to a diagonal horn⁴; if the diagonal horn is excited with circular polarization, then the radiated pattern should be identical. N7ART has shown⁵ the diagonal horn to be a good feed, so we might expect the septum feed to be also. The version described by N7ART used phased crossed dipoles to generate circular polarization, an arrangement that seems awkward at higher frequencies. The septum could be a better way to generate circular polarization.

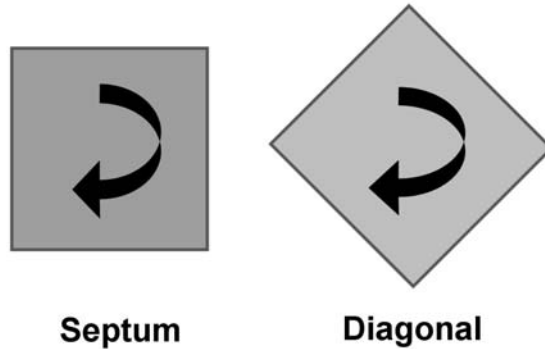

Circular Polarization

Most antennas radiate linear polarization; most communication antennas use either horizontal or vertical linear polarization. Only a few types, like the helical antenna, have inherent circular polarization. Polarization is defined as the plane in which the electric field, the E-field, varies. For example, a vertically-polarized antenna, like a vertical dipole, has an electric field which at one instant might be positive at the top and negative at the bottom; half a cycle later, it would reverse direction, to be positive at the bottom. In between, a quarter-cycle from the peaks, it would instantaneously pass through zero.

To generate circular polarization with linearly-polarized antennas, we must add a second radiator polarized at right angles to the first, and excite it a quarter cycle (90°) later than the first, so that the electric field of the second radiator reaches a peak as the first passes through zero, and vice-versa. Thus, the positive end of the electric field travels in a circle rather than just reversing along a line. Since the field is also radiating from the antenna at the speed of light as it travels in a circle, we might visualize the positive end as travelling along a corkscrew. Circular polarization is characterized by the direction of travel – right-hand (RHCP) or left-hand (LHCP), like the threads on a machine screw.

One way to excite the second radiator a quarter-cycle later is to add an extra quarter-wavelength of transmission line; choosing which linear polarization is delayed controls the direction of circular rotation. Another common method for producing the delay is the use of a 90° hybrid – a directional coupler with two outputs of equal amplitude but 90° phase difference. In waveguide, a thin dielectric sheet or card will delay energy polarized parallel to the plane of the sheet, but not perpendicularly polarized energy; the length of the sheet may be chosen to provide a quarter-wavelength of delay. A circular waveguide linearly excited at a 45° angle to a card with $\frac{1}{4}\lambda$ delay will generate circular polarization.

The 45° excitation is mathematically equivalent to two orthogonal components, but only the component parallel to the dielectric is delayed. The dielectric may be a material, like Teflon, or an artificial dielectric, for instance, a row of screws⁶ in the waveguide, adjusted to provide the desired delay for circular polarization.

The septum is a bit more complicated. A circularly polarized wave entering the aperture may be considered to have two polarization components with a 90° phase difference, one parallel to the septum and one perpendicular. The parallel component is divided equally by the septum and passes to the two rectangular input waveguides. The cutoff frequency for the perpendicular component is changed by the septum, so that the wavelength for the perpendicular component is shorter. Thus, the electrical length of the septum is longer for the perpendicular component than for the parallel component; if the difference in length is $\frac{1}{4} \lambda$, or 90°, then the horizontal and vertical components arrive in phase at the input. The components add together on one side and cancel on the other, depending on the sense of circular polarization, so that the two ports are isolated from each other. In order to achieve the difference in electrical lengths in a reasonable physical distance, the septum polarizer operates near the cutoff wavelength of the waveguides.

Figure 4 shows the simulated E-field distribution in a transparent septum feed, with the polarization component perpendicular to the septum visible through the left wall and the parallel component visible through the top wall. The red areas of high field intensity are separated by $\frac{1}{2} \lambda_g$ along each wall, so we can see that the top and side are $\frac{1}{4} \lambda_g$ apart at the aperture end, but go through a more complex difference around the steps in the septum. The cancellation at the input probe on the far side is also clear.

The first septum polarizers⁷ used a sloping septum, with a linear taper around 30°, like the cartoon cutaway in Figure 5. This version apparently⁸ offered limited bandwidth and isolation, so the stepped septum⁹ was developed to improve isolation and bandwidth. These references state that the field solution around the septum is very difficult so no analytic procedure is available. However, Chen & Tsandoulas⁹ show an example with dimensions. OK1DFC used their dimensions to build a spreadsheet that scales the design for other frequencies. Since the example is for a 0.635λ square horn, and we don't know how to calculate septum dimensions for other horn sizes, we are limited to this size horn for the septum section. It should work equally well at any frequency as long as all the dimensions are scaled.

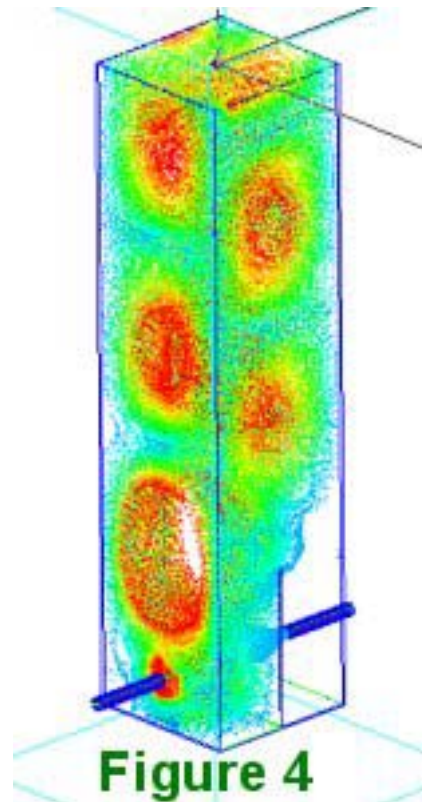

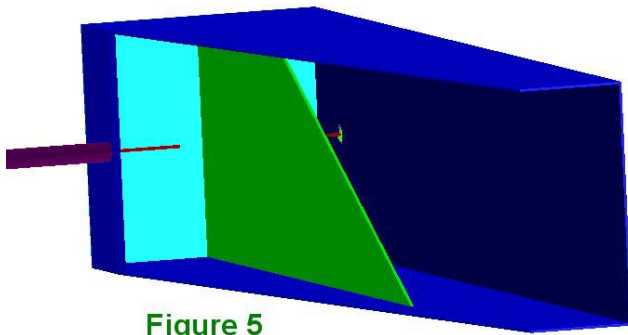

Figure 5

When I originally analyzed the septum feeds, I saw that the polarization ratio, the ratio of desired to undesired polarizations, was high. Thus, I felt it would be reasonably accurate to calculate efficiency using only the desired circular polarization. Later, I noticed that some of the septum variations had large rear lobes containing undesired polarizations, even though the

polarization ratio in the main lobe was large. As a result, I modified the efficiency calculation to more correctly calculate efficiency as the energy illuminating the dish with the desired polarization divided by the total power in all polarizations, integrated over the reflector as described by Cutler¹⁰ and W7PUA¹¹.

Simulations

A septum feed for 1296 MHz with dimensions specified by OK1DFC was simulated using Ansoft **HFSS** software¹². The calculated radiation patterns in Figure 6 show the broad illumination expected of a small horn. Like other open waveguide feeds, the rear lobes are relatively large, only about 10 dB down, reducing the calculated efficiency. The efficiency is further reduced by cross-polarization (**XPOL**) losses to about 61%, with best f/D around 0.35 to 0.4. Cross-polarization losses are due to the wasted energy in polarizations other than the desired sense of circular polarization, since the undesired polarizations will not be received by a circularly polarized antenna. In Figure 6, the total radiated power is included in the polar plot in addition to the RHCP (right-hand circular polarization) radiation pattern. The main lobe, which would illuminate a dish, consists almost entirely of RHCP energy, so the radiation in the beam reflected from the dish would have good circular polarization. However, the side and back lobes contain significant energy in unwanted polarizations, spillover energy which is lost and reduces dish efficiency.

The patterns for right and left-hand circular polarization, when excited by the appropriate input port, are pretty much identical. Patterns were calculated for both probe excitation and rectangular waveguide excitation; they were very similar, showing that the distance from the probe to the septum is adequate.

Previous simulations of diagonal feeds¹³ with linear polarization showed good radiation patterns, but with efficiency reduced by the large rear sidelobes typical of open waveguide feeds. Square horns¹⁴, with linear polarization parallel to the sides, show large additional sidelobes in the E-plane. Since the circular polarization vector is constantly rotating between these two conditions, we might expect the radiation pattern to

OK1DFC Septum feed with step polarizer, RHCP at 1296 MHz

Figure 6

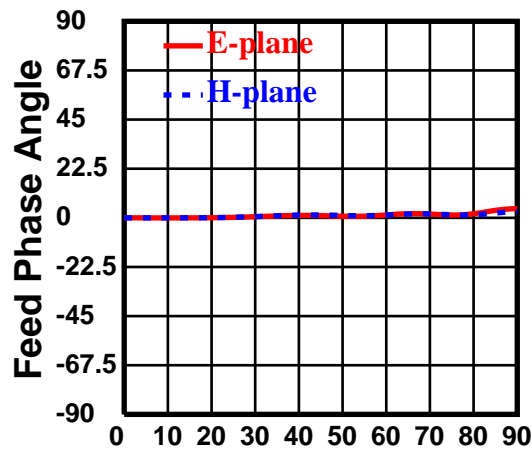
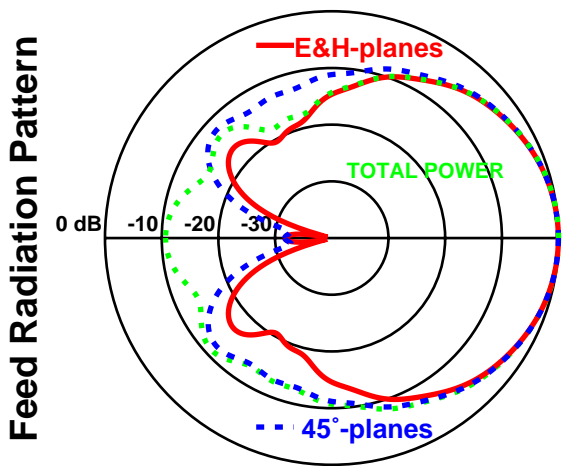

Dish diameter = 10λ Feed diameter = 0.9λ

Rotation Angle around specified Phase Center = 0λ beyond aperture

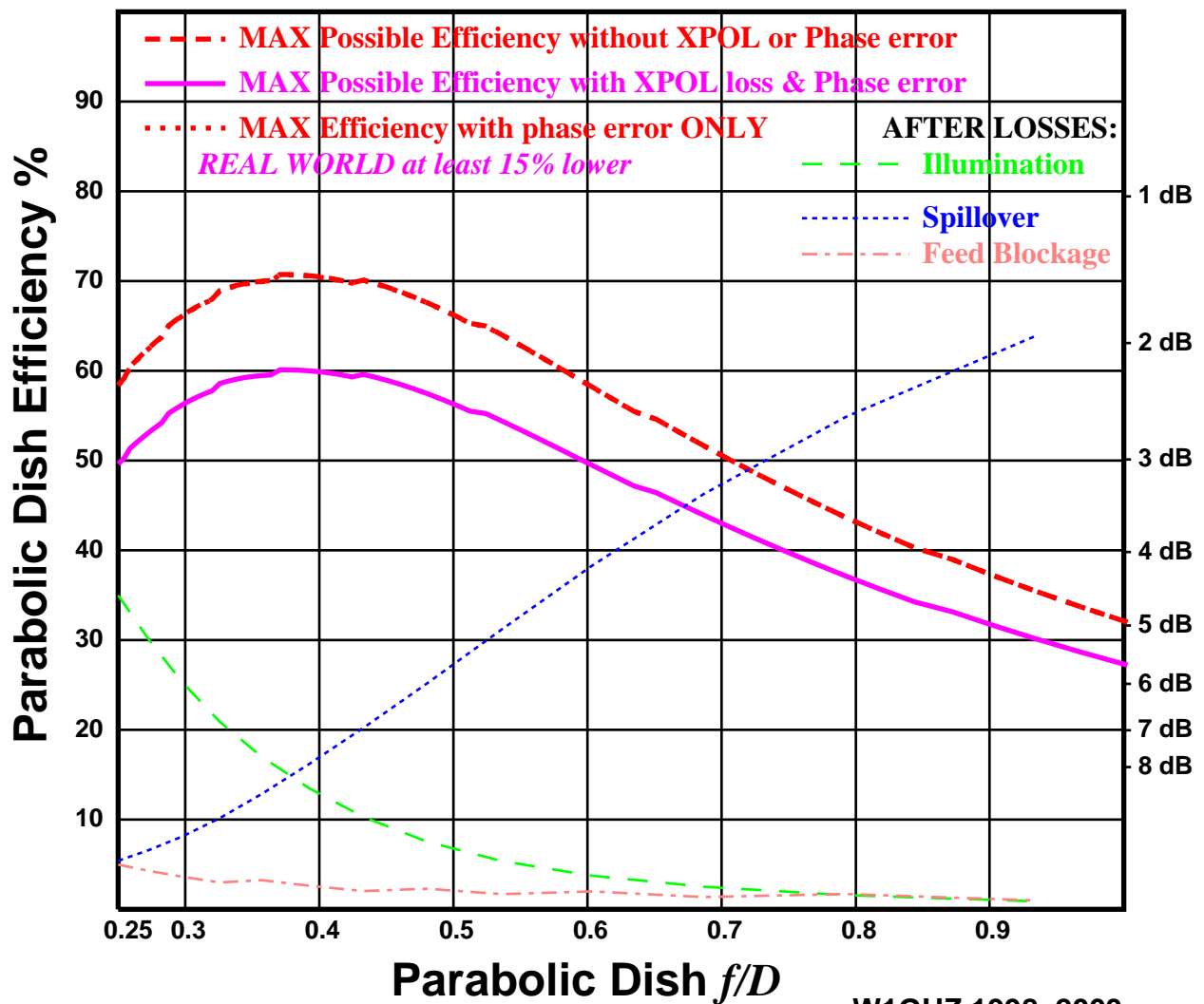

be a composite of a diagonal horn and a square horn. The circularly polarized pattern of the septum feed, shown in 3D in Figure 7, looks like we might imagine this composite, showing sidelobes on the four corners like the diagonal horn, generated as the polarization vector passes through horizontal and vertical polarization in the square horn. The sidelobes on the corners reduce the calculated efficiency compared to a calculation using only the traditional horizontal and vertical pattern cuts.

ADPRHCP (dB) at 1296 MHz
Figure 7

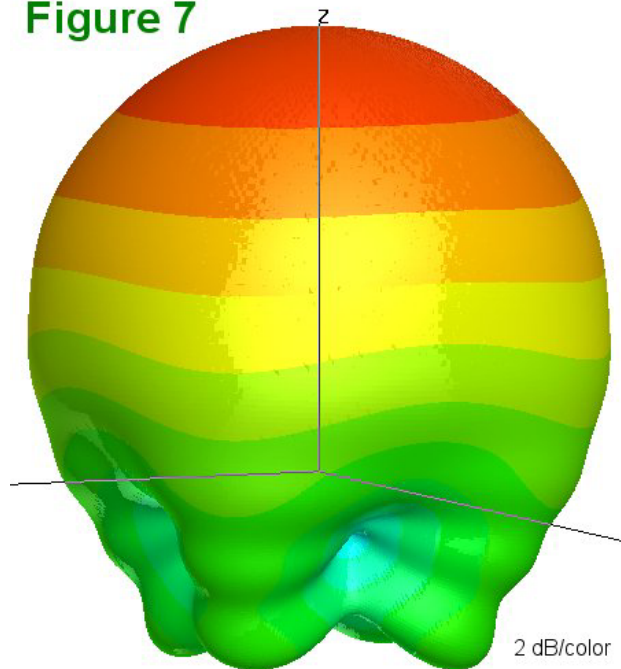

The circular polarization is quite good, with cross polarization about 21 dB down in the main lobe, and the pattern circularity is good. Isolation between the two ports is about 24 dB at 1296 MHz, with reasonable bandwidth, showing good isolation from at least 1.2 to 1.4 GHz. Note that reflection from the parabolic reflector reverses the sense of circular polarization, so that the reflection coming back into the horn will appear at the other port and reduce the isolation.

Simulation of the version with a simple 30° tapered septum like Figure 5 showed performance at 1296 MHz very similar to the performance of the stepped version shown in Figure 6, but the isolation between ports was high only over a smaller bandwidth, roughly 100 MHz. This is quite adequate for amateur use, and the sloping septum might be easier to fabricate at higher frequencies.

The calculated efficiency of this feed is not as high as some. High efficiency feeds often have a larger blockage shadow, so the septum feed may be the best performer on a small dish where circular polarization is required.

Variations

The OK1DFC septum feed consists of three sections: the input excitation, the septum polarizer, and the radiating aperture. The input excitation can be provided by a waveguide transition or by a probe which provides an integral coax-to-waveguide transition. The radiation pattern is controlled only by the aperture dimensions, so we may change the aperture to adjust the pattern and provide better illumination to dishes of various f/D .

Flared horns

The radiating aperture is a simple square waveguide, equivalent for circular polarization to a diagonal horn. A diagonal horn may be tailored to illuminate a desired f/D by varying the dimensions of the diagonal section, or by adding a flared section for larger f/D . Since we only know the correct dimensions a septum to generate circular polarization for one waveguide dimension, 0.635λ , the square cross-section is fixed at 0.635λ for a given operating frequency. However, a flare section may be added to increase the aperture size to optimize the horn for any larger f/D , so that the septum feed may be used for any dish with $f/D > 0.3$. Since there are no good feeds for very deep dishes, the septum feed is probably as good as any for deeper dishes.

The flare section is similar to a rectangular waveguide horn, except that it should maintain a square cross-section. Rectangular horns need different aperture dimensions in the E- and H-planes to achieve the same beamwidth, but the circular polarization of the septum feed has no fixed planes – they are constantly rotating in a circle – so the square cross-section should be maintained. The flare should have a gentle taper, like the cartoon in Figure 8, with one wall cut away to reveal the septum.

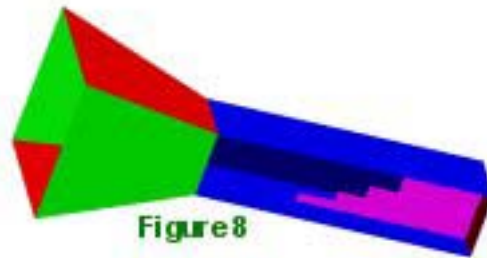

ADPRHCP (dB) at 1296 MHz
Figure 10

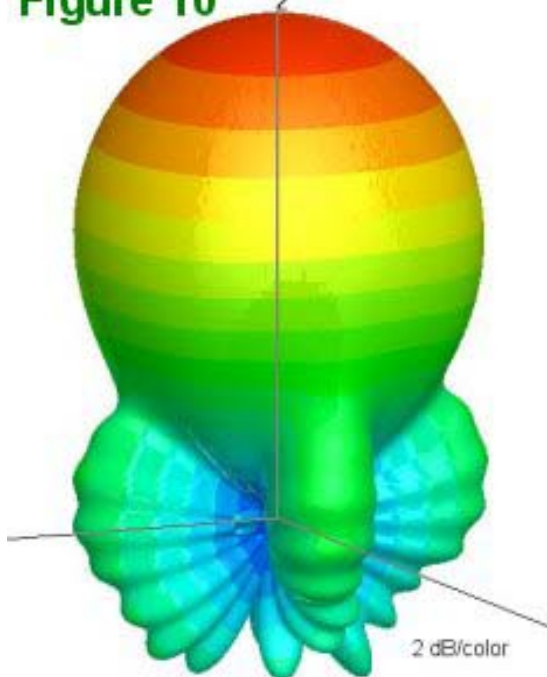

I first tried adding a flare section with an aperture 1.4λ square and a flare angle of 30° (15° halfangle on each side of the septum), since this size diagonal horn with linear polarization is a good feed for an offset dish with an equivalent f/D around 0.7. With the septum feed generating circular polarization, the calculated efficiency in Figure 9 is best for f/D is around 0.7 to 0.85, suitable for many offset dishes. This horn also had high rear sidelobes on the corners, so that the 3D pattern for RHCP in Figure 10 looks like a rocket with fins. These sidelobes are even larger when undesired polarizations are included, reducing the calculated efficiency to about 66% when feeding an offset dish.

An intermediate size flare, with an aperture 1.1λ square, produces the radiation patterns in Figure 11 with about 66% calculated efficiency at intermediate f/D , best around

Septum feed with horn flare to 1.4λ sq aperture, RHCP at 1296

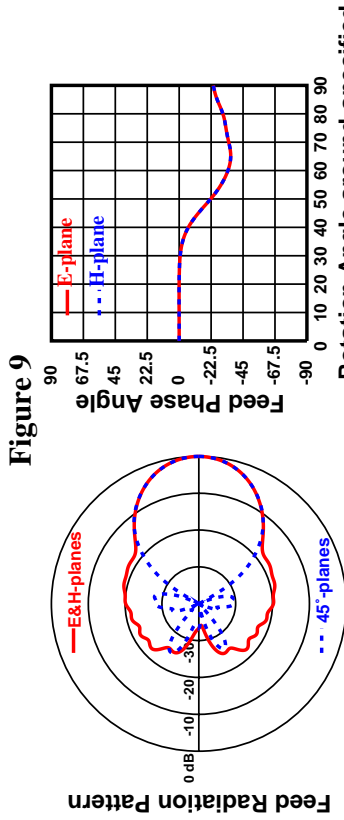

Dish diameter = 10λ Feed diameter = 0.5λ Rotation Angle around specified Phase Center = 0.2λ inside aperture

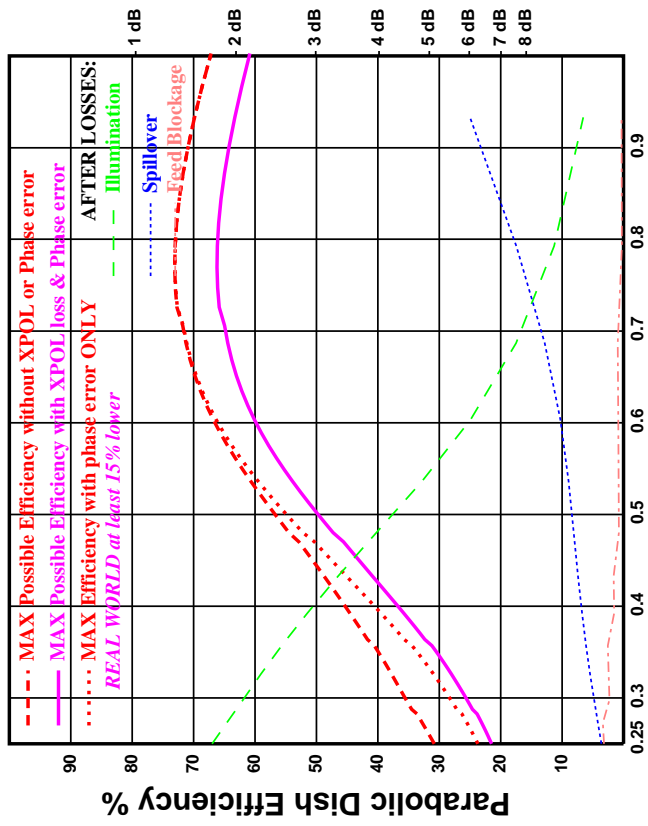

Parabolic Dish f/D

W1GHZ 1998, 2003

Septum feed with horn flare 1.1λ square, RHCP at 1296 MHz

Figure 11

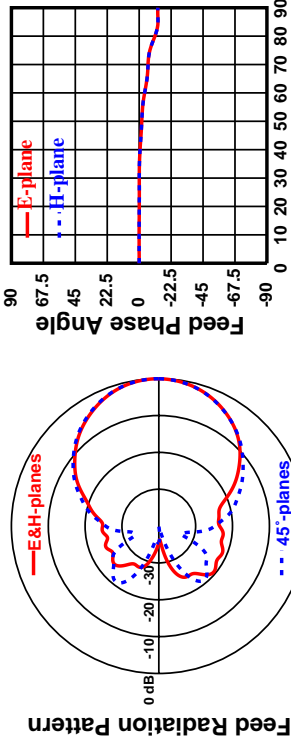

Dish diameter = 10λ Feed diameter = 1.5λ Rotation Angle around specified Phase Center = 0.04λ inside aperture

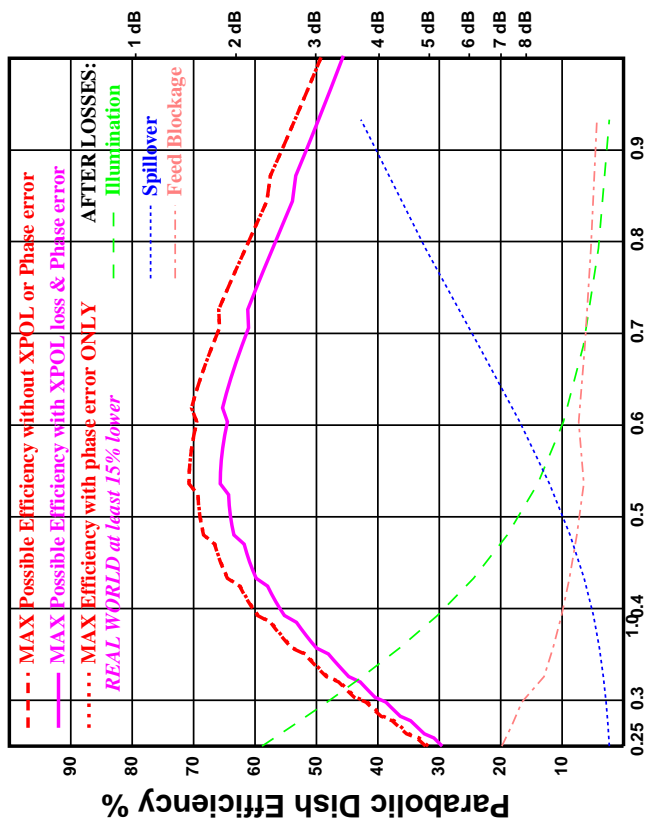

Parabolic Dish f/D

W1GHZ 1998, 2003

0.5 to 0.6. The corner lobes for this horn are less pronounced in the 3D pattern, Figure 12, and have less effect on efficiency.

Since the corners produce undesired sidelobes, I tried cutting them off and making the flare sections octagonal. The results, shown in Figure 13 for a 1.4λ aperture and Figure 14 for a 1.1λ aperture, have significantly lower XPOL (cross-polarization) loss. Calculated efficiency for both sizes increases to about 70%.

The flared septum horns show good isolation and cross-polarization in the main lobe. Since horn beamwidth is inversely related to aperture size, we can choose an appropriate aperture for the flare for any f/D by interpolating between the results for the three sizes above, 0.63λ square, 1.1λ square, and 1.4λ square. For smaller apertures, the flare angle should be small so that the flare length is reasonably long.

ADPRHCP (dB) at 1296 MHz

Figure 12

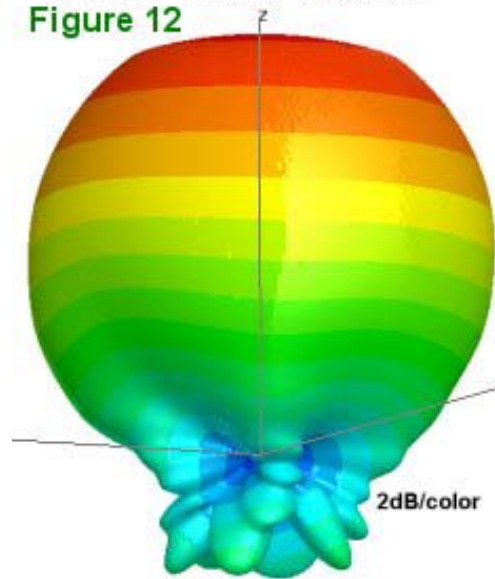

Chokes

The VE4MA feed¹⁵ adds a choke ring around a circular waveguide feed to reduce side and back lobes, thus increasing feed efficiency by putting more of the energy on the reflector. Since the unflared septum feed has rather large rear lobes, perhaps a choke would

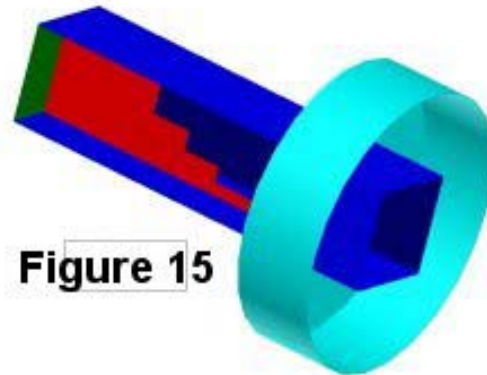
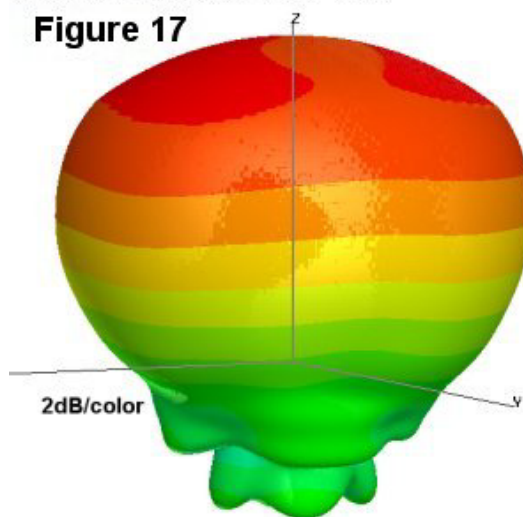

Figure 15

ADPLHCP (dB) at 1296 MHz

Figure 17



improve the septum feed also; the cartoon in Figure 15 shows one with a circular choke and one wall cut away to reveal the septum. Adding a circular choke with the same dimensions as the VE4MA feed, 419 mm in diameter and 121 mm deep at 1296 MHz, resulted in a significant reduction in the back lobes, as shown in Figure 16. Calculated efficiency improved to 63% with best f/D around 0.4 with the choke rim flush with the horn aperture. Sliding the choke back 10 to 20 mm favors deeper dishes, with best f/D around 0.35, but sliding the choke further back brings out the corner lobes and reduces

Septum feed flared to 1.4λ octagonal horn, RHCP at 1296 MHz

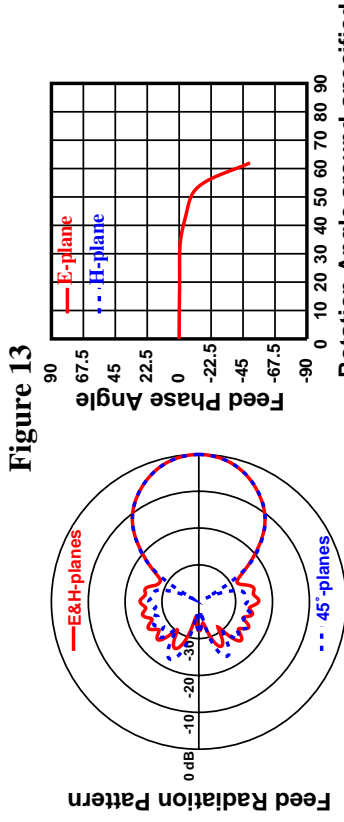

Dish diameter = 10λ Feed diameter = 0.5λ

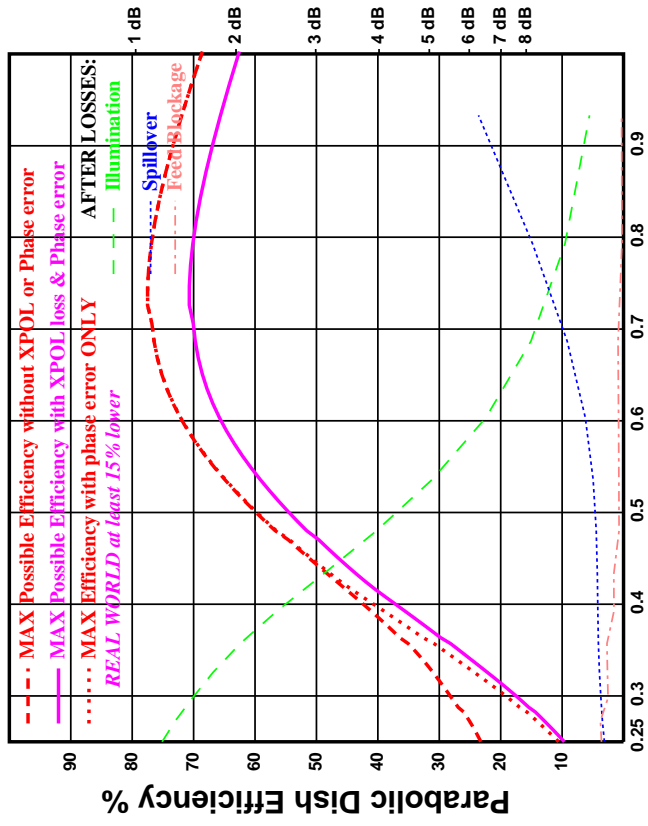

Parabolic Dish f/D

W1GHz 1998, 2003

Septum feed flared to 1.1λ octagonal horn, RHCP at 1296 MHz

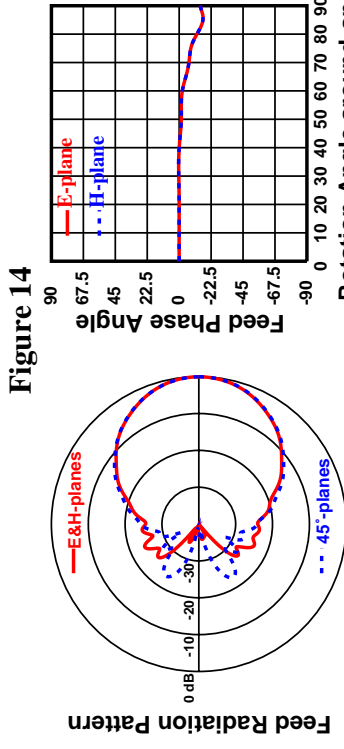

Dish diameter = 10λ Feed diameter = 1.1λ

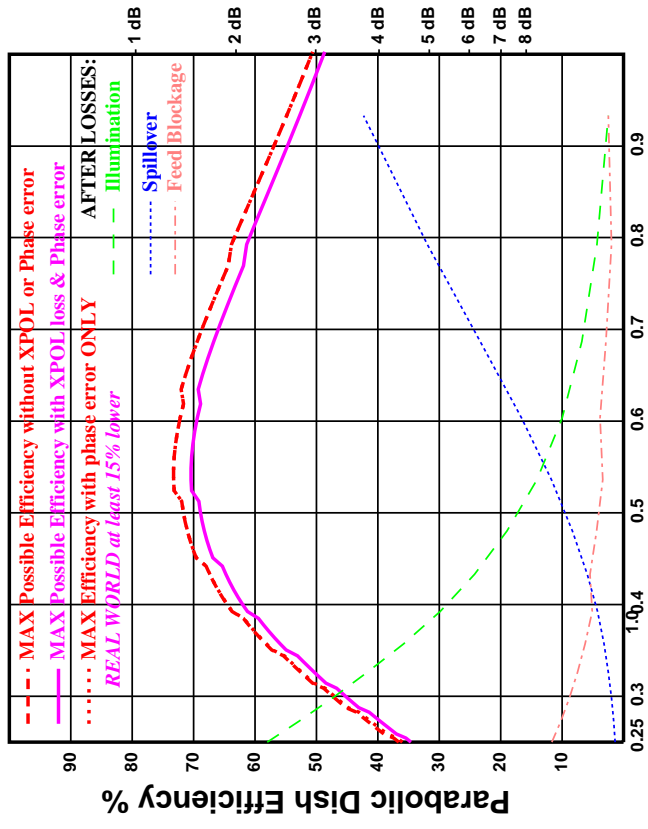

Parabolic Dish f/D

W1GHz 1998, 2003

efficiency. The 3D pattern with the choke flush, Figure 17, shows that the round choke eliminates the corner lobes. Isolation between the ports is still good, but the cross-polarization ratio is slightly lower at about 19 dB. However, the increased efficiency comes at a price: the blockage shadow has increased from 0.63λ square to 1.8λ diameter, a significant difference for a small dish. The improvement would be greater on a larger dish with smaller blockage loss.

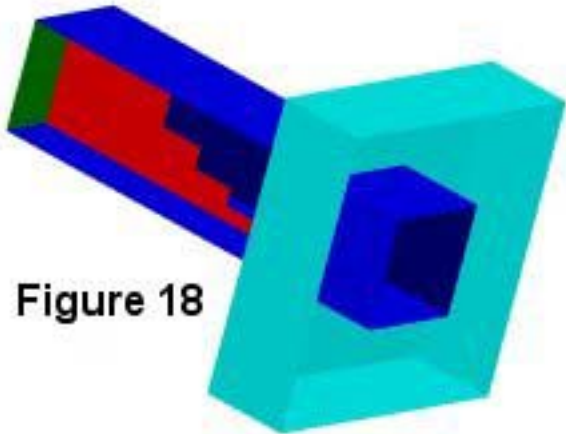

Figure 18

Since the septum feed may be fabricated by cutting and bending sheet metal, it seemed that a square choke like the cartoon in Figure 18 might be easier to fabricate than a round one. From the round choke, I estimated choke dimensions of 1.7λ square and the same 121 mm deep. As shown in Figure 19, the square choke does not work nearly as well as the round one, with very low efficiency and a 3D pattern, in Figure 20, resembling a pepper.

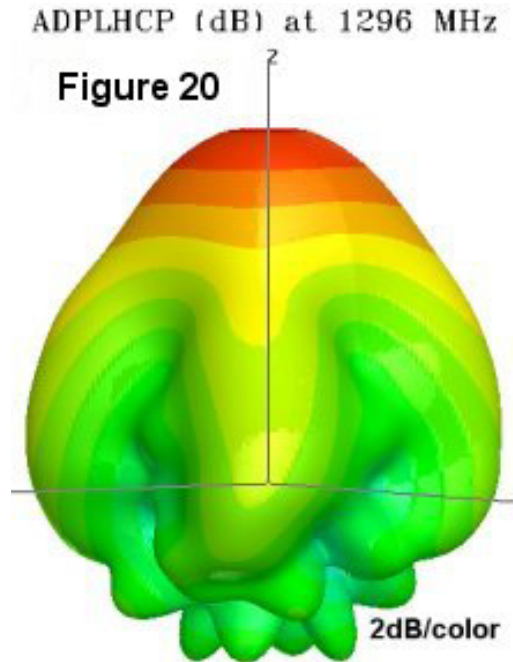

Figure 20

Circular waveguide with septum polarizer

The septum polarizer seems to do a good job of producing circular polarization in a square cross-section, with no adjustment required. Would a septum polarizer work in circular waveguide? One reference¹⁶ described a stepped septum in circular waveguide, talked about using a computer program to solve the wave equation, and plotted the relative cutoff wavelengths of the parallel and perpendicular components vs. step height. Unfortunately, the authors found that the septum dimensions had to be adjusted experimentally to achieve the 90° phase shift necessary for circular polarization.

Septum feed with round choke flush, RHCP at 1296 MHz

Figure 16

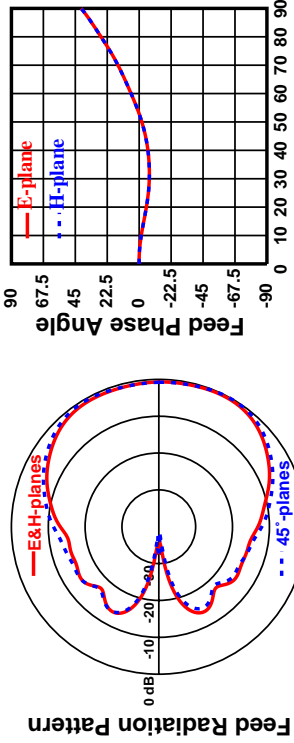

Dish diameter = 10λ . Feed diameter = 1.8λ .
 Rotation Angle around specified Phase Center = 0.3λ inside aperture

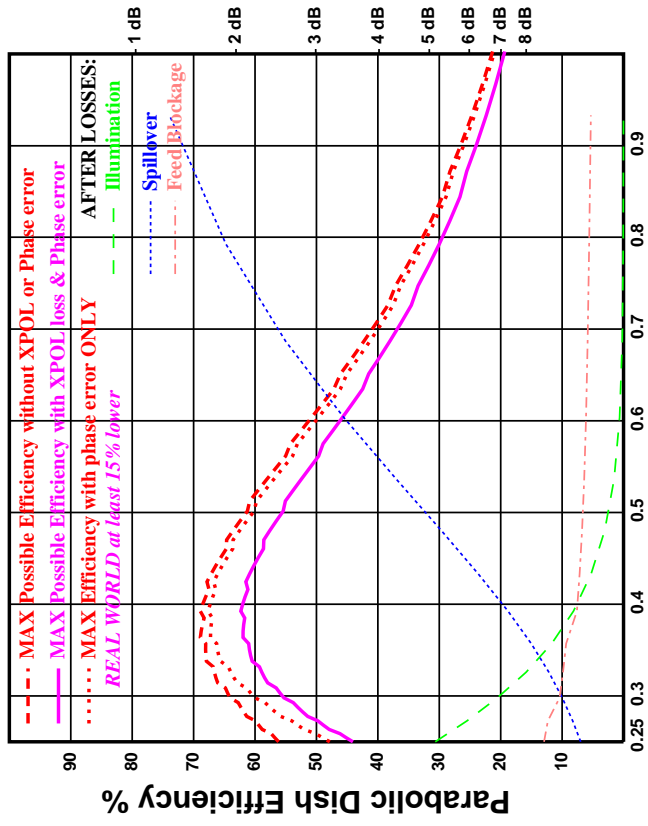

Parabolic Dish f/D

W1GHZ 1998, 2003

Septum feed with 1.7λ square choke, RHCP at 1296 MHz

Figure 19

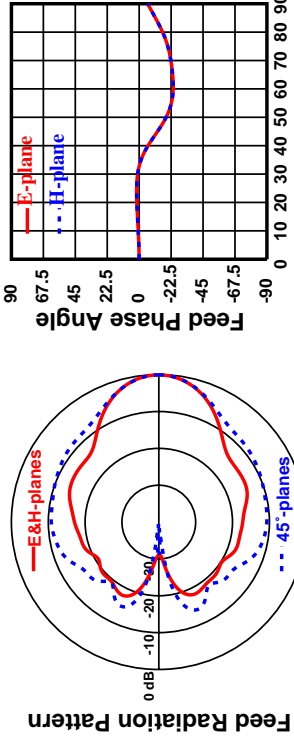

Dish diameter = 10λ . Feed diameter = 1.8λ .
 Rotation Angle around specified Phase Center = 0λ beyond aperture

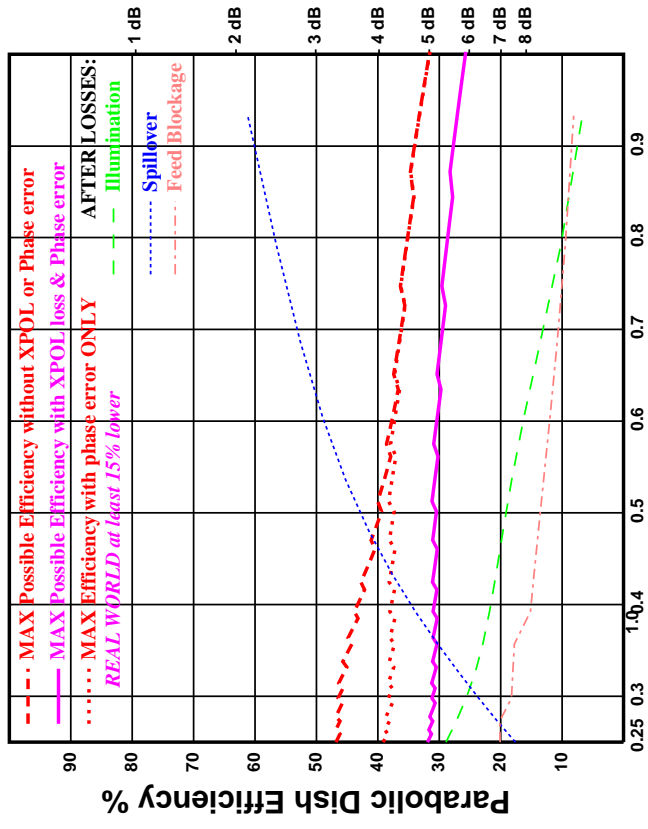

Parabolic Dish f/D

W1GHZ 1998, 2003

VE4MA feed

The simplest septum polarizer is just a linear taper, and it seems to work well in the square feed. Davis, et. al., suggest⁷ 30° as an appropriate taper for a septum polarizer, so I added a 30° sloping septum to a VE4MA feed¹⁵ with relatively small diameter circular waveguide, so that it would be close to cutoff. The resulting radiation patterns were OK, but the polarization ratio (the ratio of desired to undesired polarization) was not: the undesired sense was only about 10 dB down, so that efficiency would be reduced since about 1/10th of the energy is in the wrong polarization.

The polarization ratio was also sensitive to frequency, so I fiddled with the waveguide diameter. The best I could find with a 30° septum taper was about a 13 dB polarization ratio, at a waveguide diameter of about 0.7λ . Since this is far worse than the stepped taper in a square guide, perhaps the stepped taper might be needed in a circular guide also.

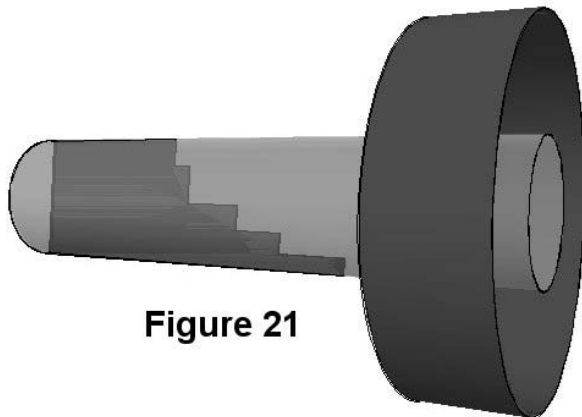
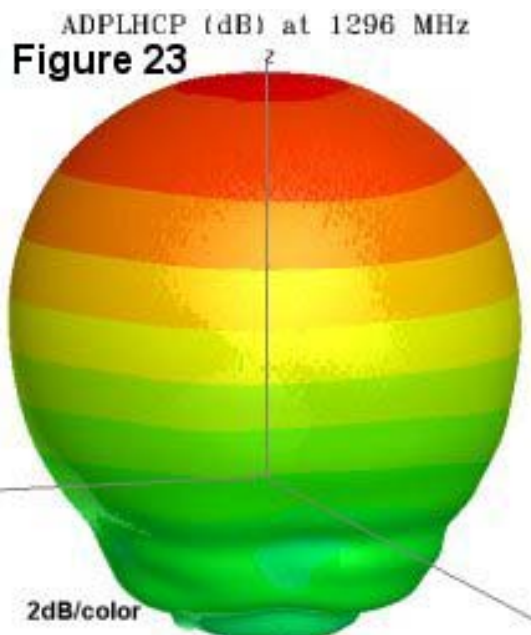

Figure 21

VE4MA feed with these dimensions has a polarization ratio around 22 dB at 1296 MHz, and good isolation between ports. The calculated radiation patterns and efficiency are shown in Figure 22; best calculated efficiency is about 61% at an f/D around 0.35 to 0.45. This efficiency is similar to the original square septum feed – the improved illumination is negated by a larger blockage shadow. As might be expected, the 3D pattern in Figure 23 has no corner lobes, since all the cross-sections are round – the aperture is axisymmetric.

Lacking a spreadsheet for circular guide, I decided to try a quick approximation. I adjusted the frequency in Zdenek's spreadsheet¹ for square guide until the septum height matched the 0.7λ waveguide diameter, then used the calculated step dimensions. A cartoon of this feed is shown in Figure 21. I don't know whether these are the best dimensions, but they work pretty well: a



VE4MA feed 0.71λ dia with step septum, RHCP at 1296 MHz

Figure 22

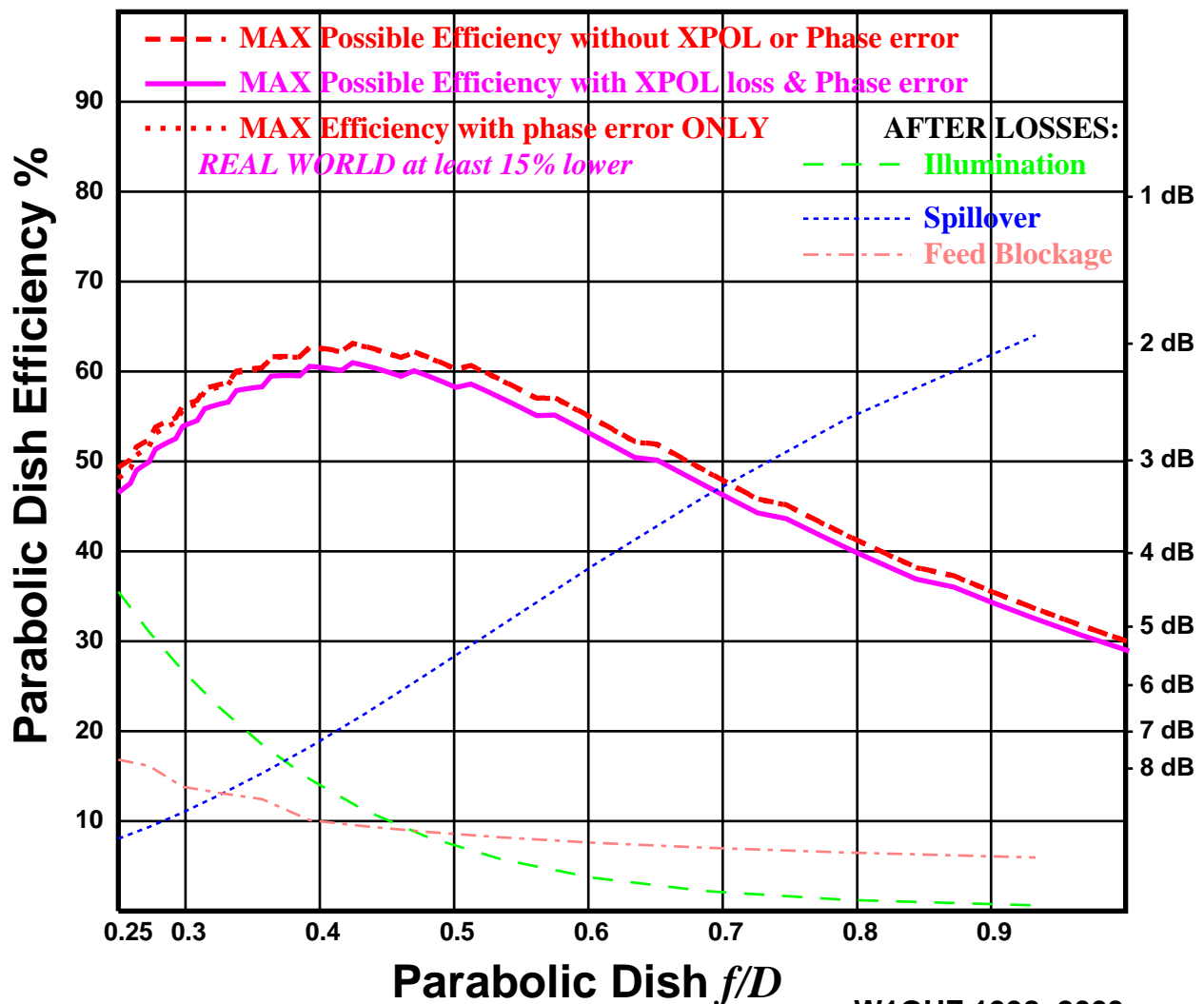
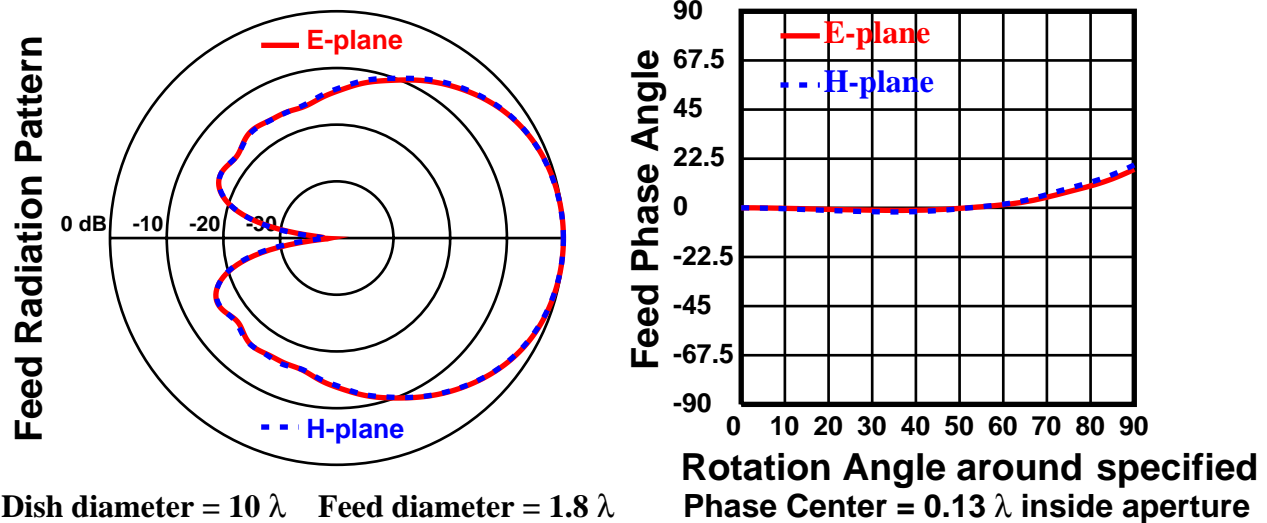

Coffee-can feed

To verify that the septum polarizer works in circular waveguide, I calculated radiation patterns for a simple open-ended circular waveguide, the popular coffee-can feed. Figures 24 and 25 show the radiation patterns and feed performance for a 0.71λ diameter open waveguide with slope and step septums, respectively. The two patterns, with total power in all polarizations shown also, are noticeably different, so the two types of septums are not equivalent in circular waveguide. With the step polarizer, calculated efficiency was good, about 65%, while the efficiency with the slope polarizer was lower due to larger XPOL loss. For either, f/D for best efficiency is about 0.35. Like the VE4MA feed, slope septums and other diameters did not work as well, since we do not know how to compensate the septum dimensions. This looks like a good feed for small dishes where feed blockage is an important consideration.

W2IMU dual-mode feed

A number of good feeds are based on circular waveguide. Once we have established that the septum polarizer works in circular waveguide, all these

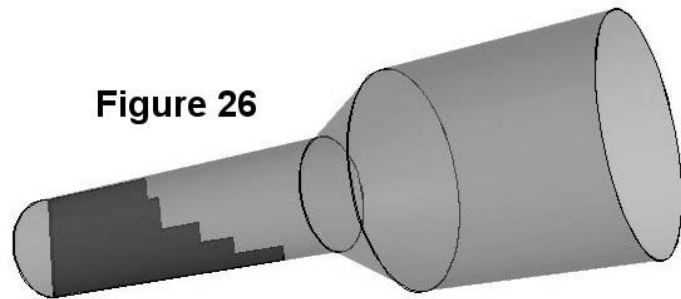

Figure 26

ADPRHCP (dB) at 1296 MHz

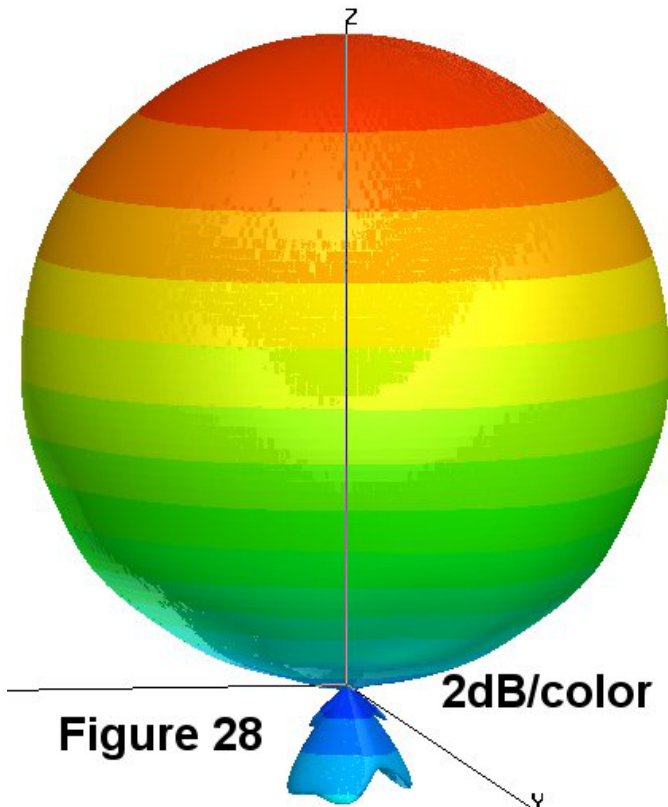
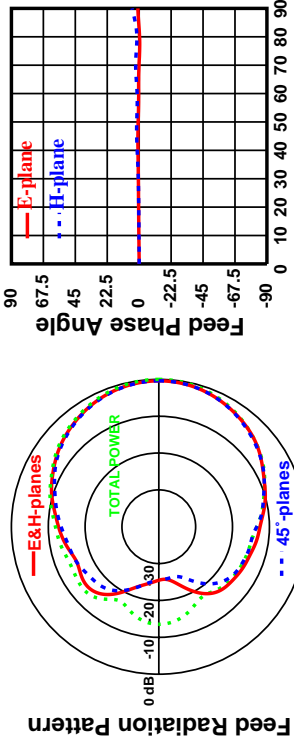

Figure 28

feeds are possible candidates. A popular one with good performance is the W2IMU¹⁷ dual-mode feedhorn, known to provide good circular polarization using conventional techniques. With a septum polarizer, like the cartoon in Figure 26, the W2IMU feed provides very good performance. As shown in Figure 27, the calculated efficiency is about 73% at an f/D around 0.66. The dual-mode feed is designed to have low sidelobes, which helps to minimize XPOL loss. The 3d view of the radiation pattern shown in Figure 28 illustrates the low sidelobes.

Coffee-can feed 0.71λ dia with slope septum RHCP at 1296

Figure 24



Dish diameter = 10 λ. Feed diameter = 0.71 λ. Rotation Angle around specified Phase Center = 0.03 λ beyond aperture

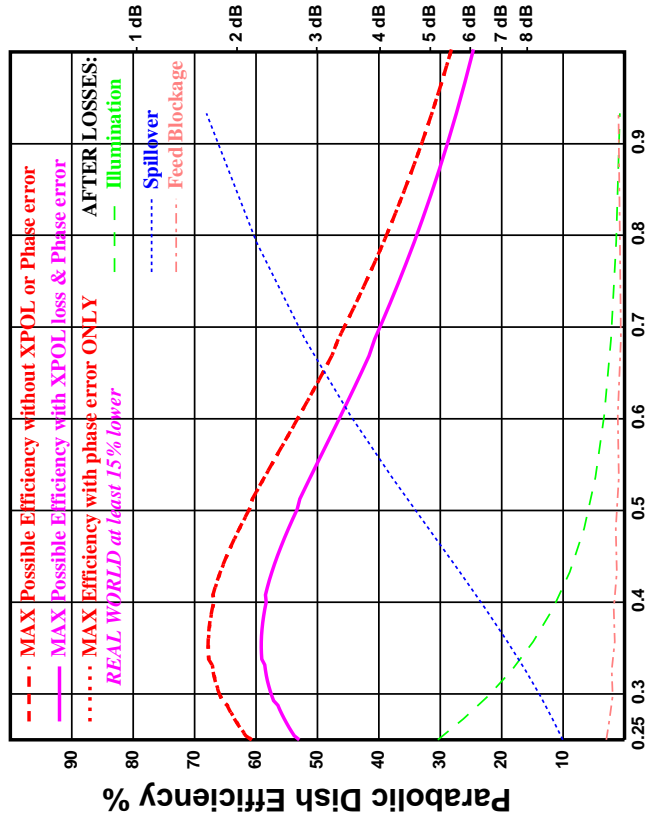

Parabolic Dish f/D

W1GHz 1998, 2003

Coffee-can feed 0.71λ dia with step septum RHCP at 1296 MHz

Figure 25

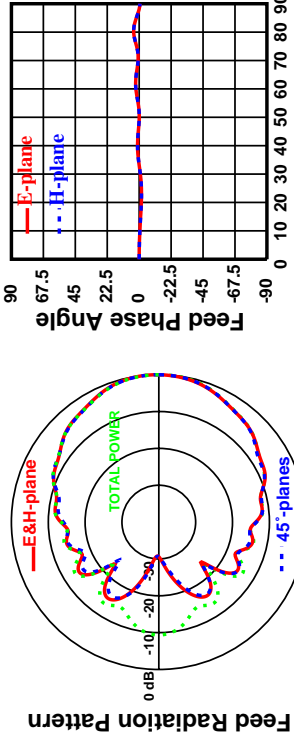

Dish diameter = 10 λ. Feed diameter = 0.71 λ. Rotation Angle around specified Phase Center = 0 λ beyond aperture

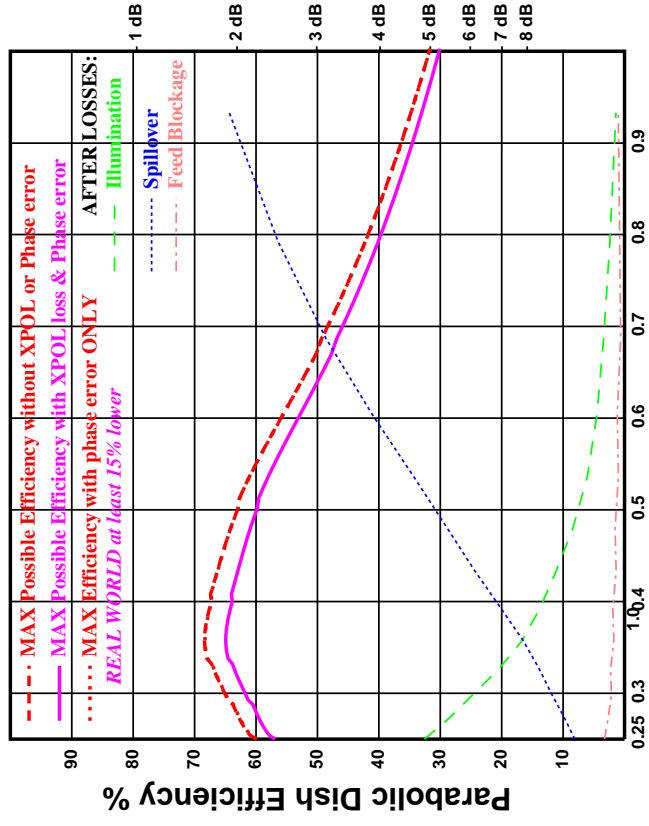

Parabolic Dish f/D

W1GHz 1998, 2003

Input probes

Since the intent was to examine feedhorn performance, these simulations were all done with single-mode waveguide excitation. The only exception was one with input probes to the OK1DFC dimensions, to make sure the probes do not affect the basic radiation pattern. The calculated patterns and efficiency were identical, but the probe version had higher isolation, shown in Figure 29. Achieving such high isolation in an actual feed would require careful construction, and then reflections from the dish surface would still reduce the isolation as described above.

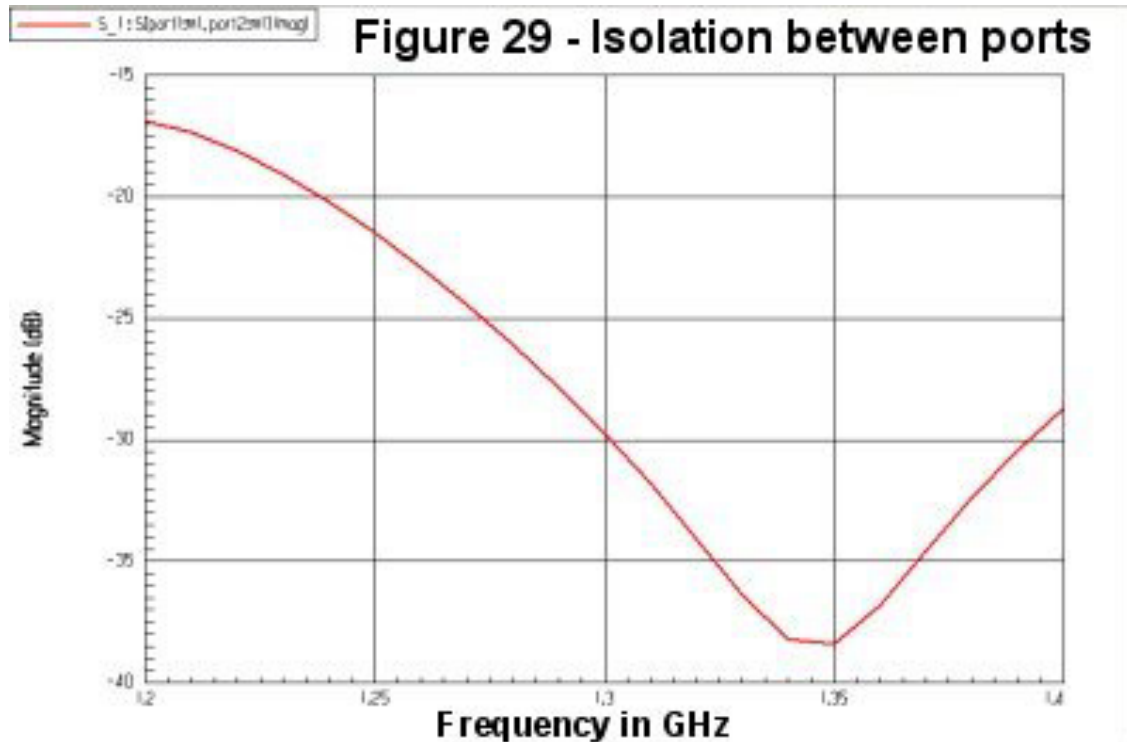

Because the septum cuts the guide in half in the input area, the probe length is limited. The optimum probe length might be very close to the septum, particularly in circular guide, close enough to arc over with high power. For the square guide, Zdenek has shortened the probe length and compensated with a tuning screw to add capacitance, a reasonable solution. A better solution would be to increase the probe diameter – at 1296 MHz, 1/4" diameter probes should provide a good match. Anyone wishing to add a septum polarizer to a VE4MA feed with probe excitation will have to empirically find probe and tuning screw dimensions for the circular guide. Since the polarization and isolation are taken care of by the septum, only the VSWR of each probe must be adjusted.

W2IMU dual-mode feed with step septum, RHCP at 1296 MHz

Figure 27

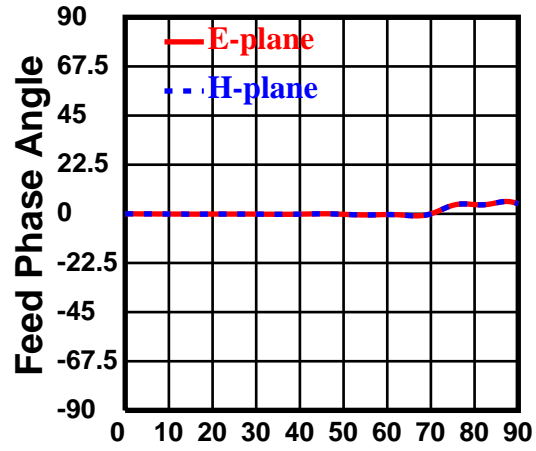
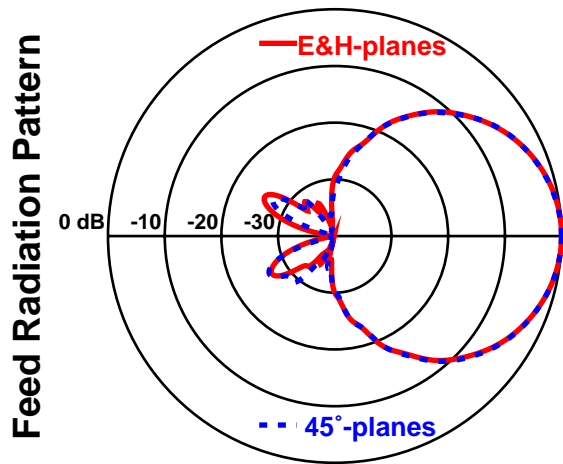

Dish diameter = 10λ Feed diameter = 1.3λ

Rotation Angle around specified Phase Center = 0.02λ beyond aperture

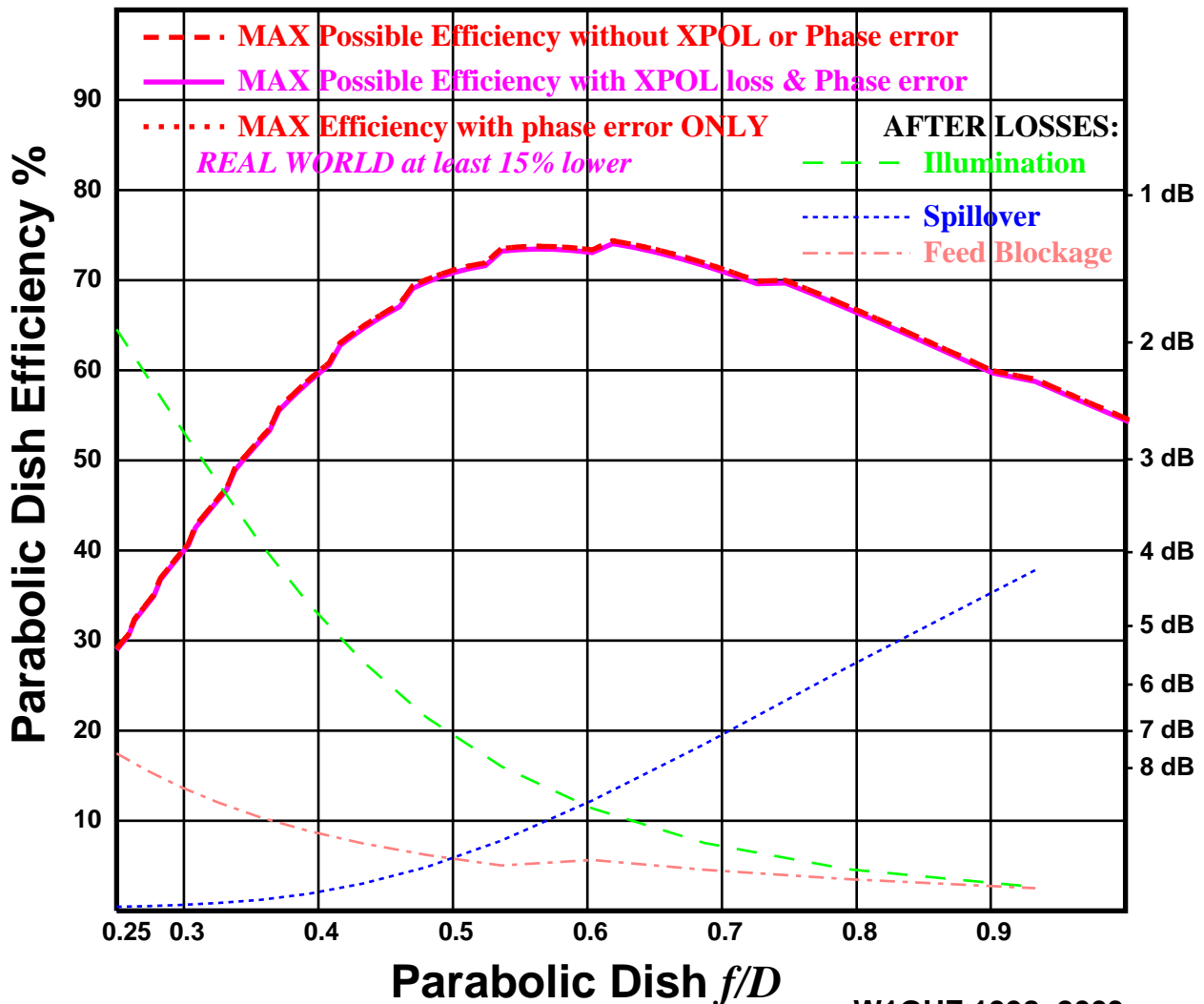

Summary

The septum feeds are impressive – the septum polarizer provides good circular polarization performance with no adjustments. The other common ways to achieve circular polarization use two orthogonal probes phased by 90° ; the phasing is achieved with an external 3-dB hybrid or a phasing section in the guide, often a series of screws, to provide a slow-wave structure for one polarization. The screws require careful adjustment to achieve good circularity and good VSWR, while the external hybrid and cabling adds some losses. The septum polarizer offers the possibility of good, low-loss, circular polarization with no adjustments.

The septum polarizer is applicable to a variety of feedhorns. The simple square cross-section described by OK1DFC is ideal for low blockage on small deep dishes, while a choke may be added for better performance on larger dishes. A flare section to increase the aperture will better illuminate shallow and offset dishes. In square waveguide, the step and slope septums both appear to work, but only the step septum polarizer works well in cylindrical horns like the VE4MA feed and the W2IMU dual-mode feed. Best performance is found on feeds with low sidelobes, since sidelobes contain unwanted polarizations and increase cross-polarization loss.

References

1. Zdenek Samek, OK1DFC, "Feed for Parabolic Dish with Circular Polarization," *10th International EME Conference 2002*, Prague, 2002. www.qsl.net/ok1dfc
2. Zdenek Samek, OK1DFC, "Information and practical hints for the construction of a septum feed," *DUBUS*, 1/2003, pp. 39-47.
3. P. Wade, W1GHZ, "Analysis of the OK1DFC Septum Feed," *DUBUS*, 1/2003, pp. 22-38.
4. A.W. Love, "The Diagonal Horn Antenna," *Microwave Journal*, March 1962, pp. 117-122. (reprinted in A.W. Love, *Electromagnetic Horn Antennas*, IEEE, 1976, pp. 189-194.)
5. R. Miller, N7ART, "A 23cm Diagonal Waveguide Feed," *DUBUS*, 2/1997, pp. 5-14.
6. D. Turrin, W2IMU, "A Circularly Polarized Feed Antenna for 1296 mc/s," *Crawford Hill Technical Report #9*, December 1971. (reprinted in *Proceedings of Microwave Update '99*, ARRL, 1999, pp. 487-491.)
7. D. Davis, O. J. Digiondomenico, and J. A. Kempic, "A new type of circularly polarized antenna element," 1967 IEEE Group on Antennas and Propagation International Symposium Digest, vol. 5, pp. 26-33, October 1967.
8. H. Schrank; Antenna designer's notebook, IEEE Antennas and Propagation Society Newsletter, vol. 25, pp. 23-24, October 1983.
9. Ming Hui Chen, G. N. Tsandoulas; A wide-band square-waveguide array polarizer, IEEE Transactions on Antennas and Propagation, vol. 21, pp. 389-391, May 1973
10. C.C. Cutler, "Parabolic-Antenna Design for Microwaves," *Proceedings of the IRE*, Nov. 1947, pp. 1284-1294. (reprinted in A.W. Love, *Reflector Antennas*, IEEE, 1978, pp. 16-26.)
11. B. Larkin, W7PUA, "Dipole-Reflector Parabolic Dish Feeds for f/D of 0.2-0.4," *QEX*, February 1996, pp. 3-11.
12. www.ansoft.com
13. P. Wade, W1GHZ, *The W1GHZ Microwave Antenna Book – Online*, Section 6.5.3, www.w1ghz.org
14. P. Wade, W1GHZ, *The W1GHZ Microwave Antenna Book – Online*, Section 6.4.2, www.w1ghz.org
15. B.W. Malowanchuk, VE4MA, "Selection of an Optimum Dish Feed," *Proceedings of the 23rd Conference of the Central States VHF Society*, ARRL, 1989, pp. 35-43.
16. R. Behe and P. Brachat, "Compact duplexer-polarizer with semicircular waveguide," IEEE Transactions on Antennas and Propagation, vol. 39, pp. 1222-1224, August 1991.
17. R.H. Turrin, (W2IMU), "Dual Mode Small-Aperture Antennas," *IEEE Transactions on Antennas and Propagation*, AP-15, March 1967, pp. 307-308. (reprinted in A.W. Love, *Reflector Antennas*, IEEE, 1978, pp. 214-215.)